

Mechanical separator using centrifugal force to remove large and high-volume dust from industrial applications.

- An economical solution to a wide range of dust collection problems.
- Excellent for high dust load, high temperature, and product recovery applications.
- Can be used alone, with optional bag filter assembly, or as a pre-cleaner.
- Applications from 300 to 13,000 cfm.
- Heavy-duty construction for long life and low maintenance.
- Meets seismic zone 4 and 100 mph wind load ratings.
- Removable cone section for easy replacement.

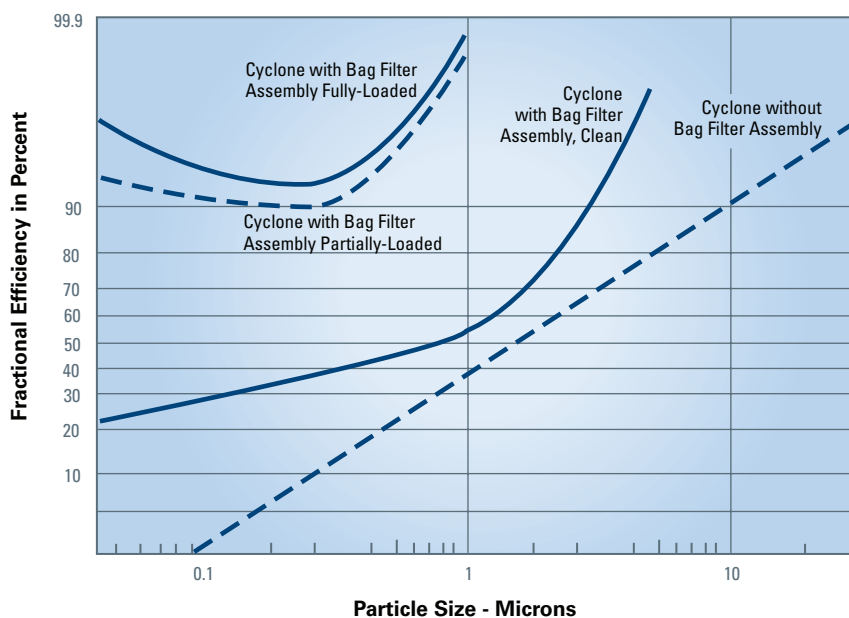

Cyclone Dust Collector
with Optional Bag Filter Assembly



Fractional Efficiency is the ratio of particles collected to particles entering the cyclone.

This chart illustrates the efficiency* of a Cyclone collector with and without an optional filter bag assembly under clean, partially-loaded, and fully-loaded filter bag conditions.

* Actual efficiency may vary depending on the application. Dust concentration, airflow, particle shape, and density affect filtration efficiency.

CYCLONE DUST COLLECTORS

OPERATIONAL EXPLANATION

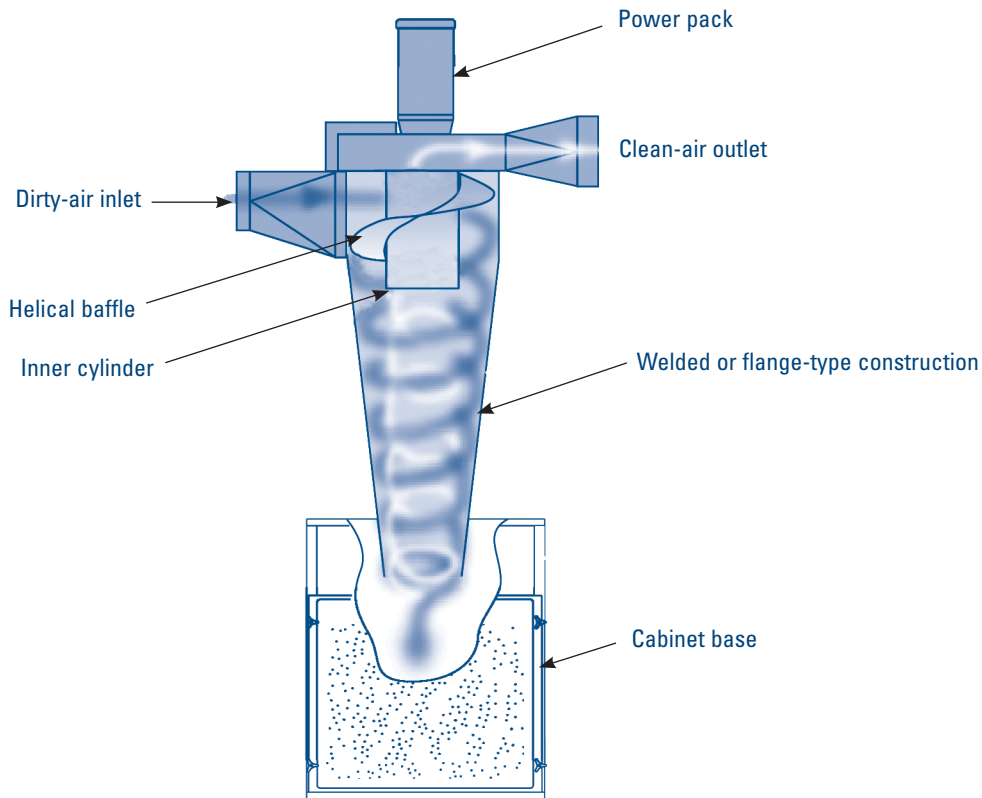

Dust-laden air enters the unit through the air inlet and is diverted by a helical baffle. Centrifugal force moves the heavy dust to the interior sidewalls and carries them to the base of the unit. Clean air is carried through the inner cylinder and discharges to atmosphere or optional afterfilters.

MULTIPLE RATING TABLE

Model	Nominal Airflow Range* (cfm)	External Static Pressure ("wg)	Inlet Velocity (fpm)
12	300 - 540	5.6 - 4.1	3580 - 6200
16	860 - 1200	7.9 - 4.6	4380 - 6135
20-3	1250 - 2000	7.5 - 3.7	3555 - 5710
20-5	1500 - 2500	11.4 - 5.0	4290 - 7140
24	1950 - 3500	13.4 - 4.4	3580 - 6450
30-10	3000 - 4500	9.9 - 5.0	3820 - 5730
30-15	4000 - 5600	11.0 - 4.9	5100 - 7140
36-20	4300 - 7000	11.4 - 4.9	4015 - 6540
36-25	4500 - 7500	14.9 - 6.3	4210 - 7010
36-30	5000 - 8000	16.1 - 7.1	4670 - 7465
44-40	8000 - 11,500	15.1 - 5.5	4530 - 6510
44-50	8000 - 13,000	18.8 - 7.0	4530 - 7360

* Based on clean bag filters.

CYCLONE DUST COLLECTORS

DIMENSIONS & SPECIFICATIONS

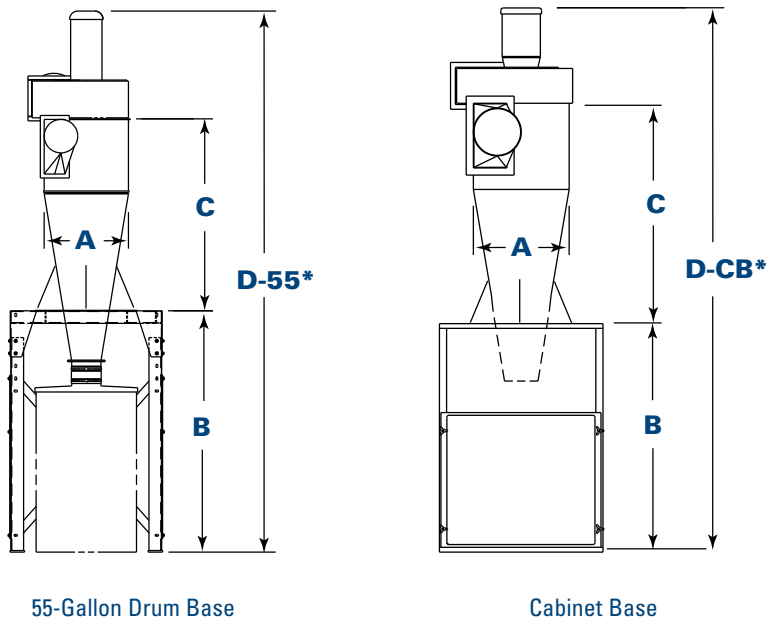

Model	Dimensions (inches)				
	A	B	C	D-55*	D-CB*
12	12	55	32	100	78
16	16	55	36	108	86
20-3	20	55	48	121	114
20-5	20	55	48	123	116
24	24	67	55	145	126
30-10	30	67	72	162	154
30-15	30	67	72	162	154
36-20	36	67	85	183	—
36-25	36	67	85	186	—
36-30	36	67	85	186	—
44-40	44	—	104	—	—
44-50	44	—	104	—	—

* Typical. May vary based on motor type/size ordered.

Model	Nominal Airflow Range* (cfm)	Optional Bag Filter Assembly		Motor (hp)	Air Inlet (in)	Air Outlet (in)	Dust Capacity (ft ³)		Shipping Weight (lbs)	
		Filter Area (ft ²)	No. of Bag Filters				Dust Drawer	Hopper	Standard	With Optional Bag Filter Assembly
12	300 - 540	15	1	¾	4	6	4.8	12.0	325	350
16	860 - 1200	25	1	2	6	8	4.8	12.0	390	410
20-3	1250 - 2000	70	4	3	8	10	8.5	19.5†	600	740
20-5	1500 - 2500	70	4	5	8	10	8.5	19.5†	640	740
24	1950 - 3500	100	4	7.5	10	12	8.5	37.5†	750	850
30-10	3000 - 4500	200	8	10	12	14	16.5	37.5†	1175	1400
30-15	4000 - 5600	200	8	15	12	14	16.5	37.5†	1210	1486
36-20	4300 - 7000	300	12	20**	14	16	—	54.0†	2000	2300
36-25	4500 - 7500	300	12	25	14	16	—	54.0†	2145	2445
36-30	5000 - 8000	300	12	30**	14	16	—	54.0†	2165	2465
44-40	8000 - 11,500	600	24	40**	18	20	—	103.0	3150	3550
44-50	8000 - 13,000	600	24	50**	18	20	—	103.0	3165	3565

* Based on clean filters.

** Model 36-20 and 36-30 available with direct- or belt-drive blowers. Model 44 available with belt-drive blower only.

† Up to 103 cu ft hopper available.

CYCLONE DUST COLLECTORS

BASE OPTIONS

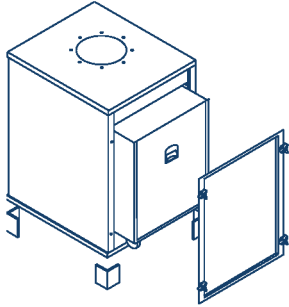

Cabinet Base

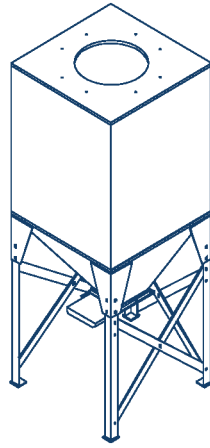

Hopper Base

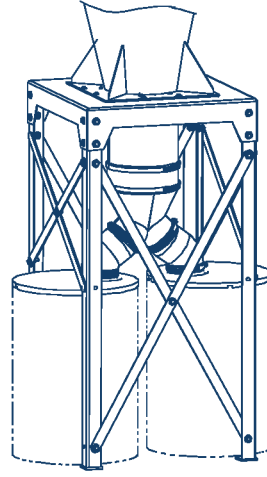

Two-Drum Style
55-Gallon Drum Base
(optional)

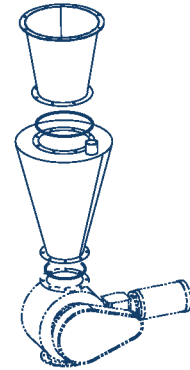

Surge Hopper
(optional)

STANDARD FEATURES & AVAILABLE OPTIONS

STANDARD	OPTIONAL
Inlet assembly	Power pack
55-gallon drum base for Models 12 through 36	Explosion-proof motors
TEFC motor (60 Hz 1 HP and larger are EISA compliant)	50 Hz, single phase motors
103 cu. ft. hopper and legs for Model 44	Steel or aluminum fan wheels
208/230/460/60/3 voltages	Hopper base
10-year warranty	Two 55-gallon drum base for Models 20, 24, and 30
	Cabinet base for Models 12, 16, 20, 24, and 30
	Surge hopper
	Silencer
	Exhaust accessories
	Attenuator
	Bag filter options
	Bag filter enclosure
	Explosion vent

Significantly improve the performance of your collector with genuine Donaldson Torit replacement filters and parts. [Browse our catalog at donaldson.com](http://donaldson.com)



Donaldson Company, Inc.
Torit
P.O. Box 1299
Minneapolis, MN
55440-1299 U.S.A.

Tel 800-365-1331 (USA)
Tel 800-343-3639 (within Mexico)

donaldson.com
donaldson.com



Data Sheet Cyclone Dust Collectors (08/11)

© 1995 Donaldson Co., Inc. All Rights Reserved. Information in the document is subject to change without notice. Donaldson Torit is a registered trademark of Donaldson Company, Inc. Contains Donaldson proprietary technology.